

LET	ECN	REVISION	DRAWN	APPVD.	DATE
A	18614	SEE ECN FOR CHANGES	BA	PJD	30 APR 03

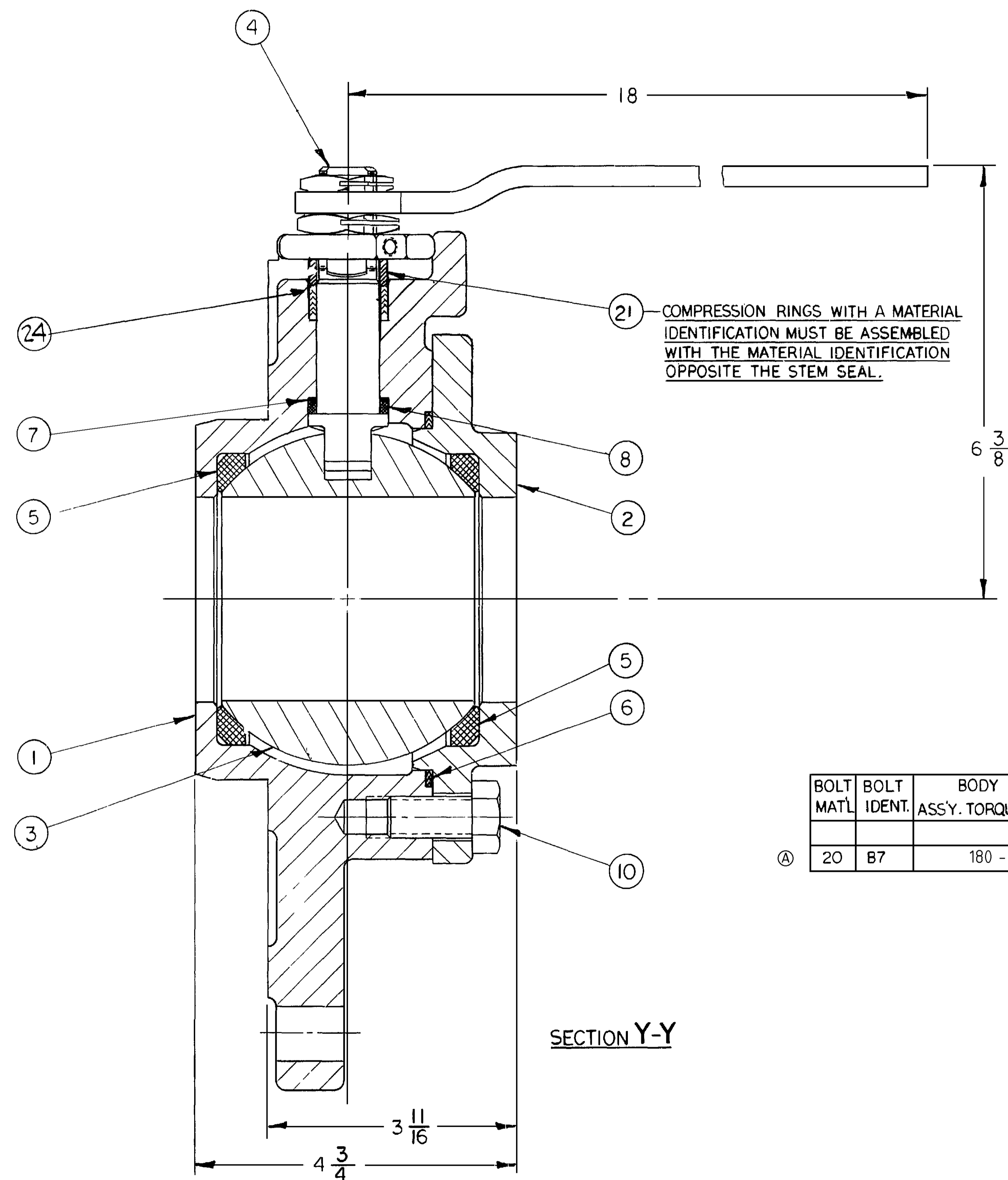

BOLT MAT'L	BOLT IDENT.	BODY CAP ASSY. TORQUE FT./LBS.
20	B7	180 - 190

ITEM NO.	PART NAME	QTY.
1	BODY	1
2	BODY CAP	1
3	BALL	1
4	STEM	1
5	SEAT	2
6	BODY SEAL	1
7	SECONDARY STEM SEAL	1
8	STEM SEAL	1
10	HEX. HD. CAP SCREW	4
12	INDICATOR STOP	1
13	SOC. HD. SET SCR.	2
15	STEM NUT	2
17	HANDLE	1
21	COMPRESSION RING	1
22	IDENTIFICATION TAG	1
23	DRIVE SCREW	2
24	UPPER STEM SEAL	1

SECTION Y-Y

JC	ALL
JL	
JM	
JN	
JS	

DEFINITION OF SYMBOLS (Total Indicator Reading) ○ CONCENTRICITY ○ ROUNDNESS ○ FLATNESS ≡ SYMMETRY    PARALLEL ⊥ PERPENDICULAR	THIS DRAWING AND ALL INFORMATION CONTAINED HEREIN ARE THE PROPERTY OF THE JAMESBURY CORP. AND ARE NOT TO BE USED EXCEPT AS AUTHORIZED BY SAID CORP.  UNLESS OTHERWISE NOTED TOLERANCE FRACTIONAL ± 1/32 TWO PLACE DECIMAL ± .01 THREE PLACE DECIMAL ± .003 ANGULAR ± 1° ALL MACHINE SURFACES TO BE ± .000 UNLESS OTHERWISE NOTED REMOVE ALL SHARP CORNERS 1/64 MAX REMOVE ALL BURRS	JAMESBURY SPECIFICATIONS AS APPLICABLE ON THIS DWG. JST-02 JSA-01 JSA-10 JSA-17 JSA-34	MAKE FROM PART NO DO NOT SCALE DRAWING TITLE ASSEMBLY 4-5REB3 MODEL B W/O STEAM JACKET	DR. BY E.C.K. CH. BY J.F. APR 03	DATE APR 03	SCALE 1:1
		jamesbury CORP. WORCESTER MASS	D 4875	SH. 1 OF 3		

D 4875

LET	EEN	REVISION	DRAWN	APPVD.	DATE
A	18614		BA	PJD	30 APR 03

D  
C  
B  
A

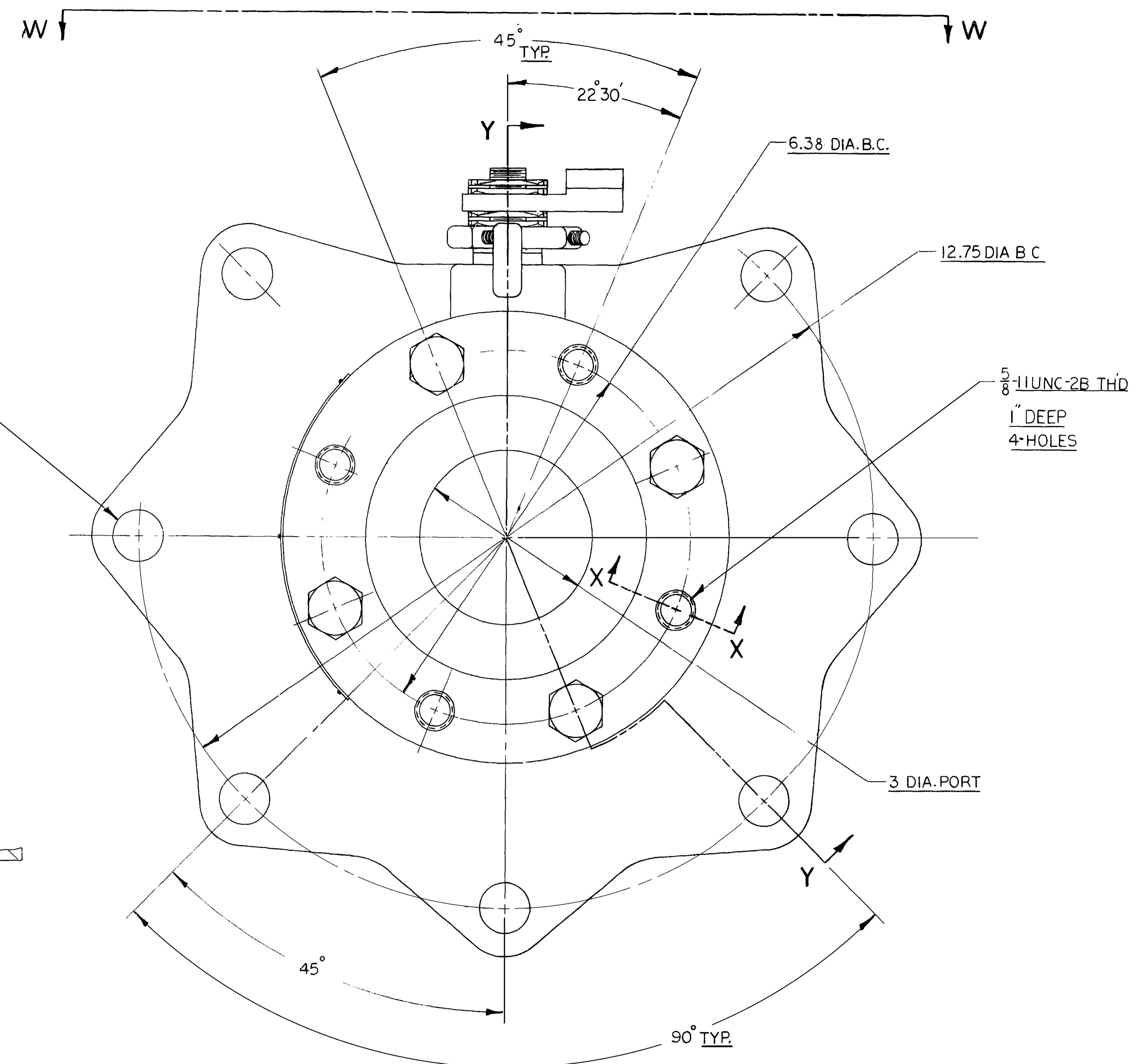

.87 DIA. THRU  
7 HOLES

5/8-11UNC-2B THD  
1\"/>

3 DIA. PORT

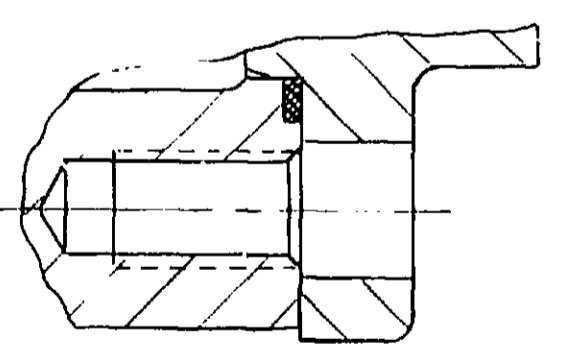

SECTION X-X

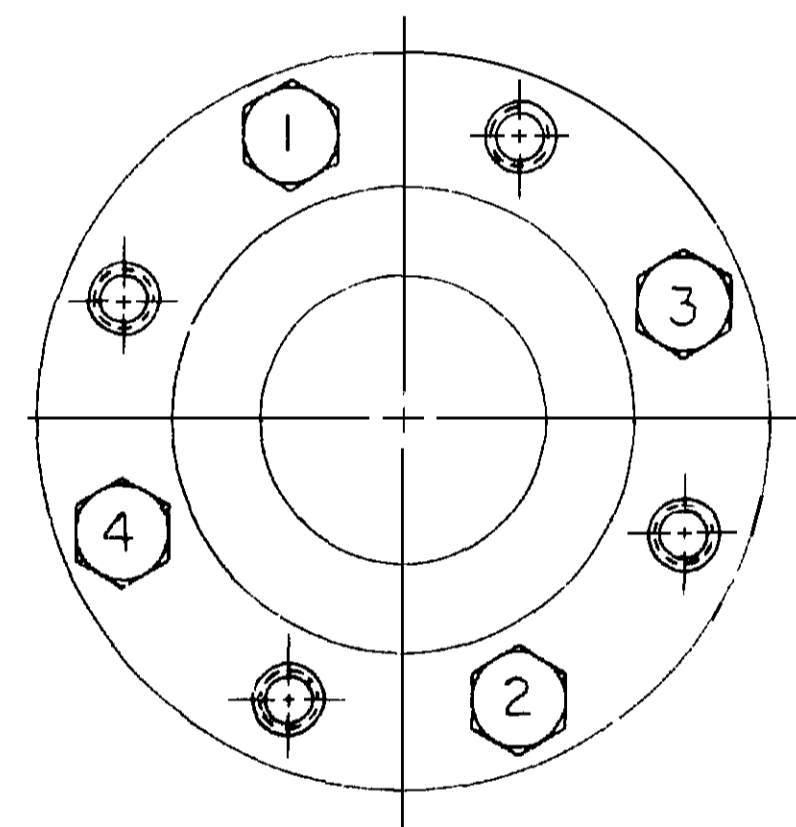

BODY CAP  
CAP SCREW TIGHTENING SEQUENCE

	JC	ALL
	JL	
	JM	
	JN	
	JS	
	JT	

DEFINITION OF SYMBOLS (Total Indicator Reading)	UNLESS OTHERWISE NOTED TOLERANCE
○ CONCENTRICITY	FRACTIONAL ± 1/32
○ ROUNDNESS	TWO PLACE DECIMAL ± .01
○ FLATNESS	THREE PLACE DECIMAL ± .003
≡ SYMMETRY	ANGULAR ± 1°
PARALLEL	ALL MACHINE SURFACES TO BE 250
⊥ PERPENDICULAR	BREAK ALL SHARP CORNERS 1/64 MAX. REMOVE ALL BURRS

MATL. CODE	MATERIAL TYPE	MATERIAL SPECIFICATIONS	IDENTIF. MARK
JAMESBURY SPEC. CAT. 015	MAKE FROM PART NO.	DO NOT SCALE DRAWING	SCALE 1:1
TITLE	DR. BY	DATE	DATE
ASSEMBLY 4-5REB3 MODEL B W/O STEAM JACKET	E.C.K.	APR 3 2006	APR 3 2006
JAMESBURY CORP. WORCESTER MASS.	D	4875	

D 4875

LET	ECN	REVISION	DRAWN	APPVD.	DATE
A	10614		BA	PJD	30 APR 03

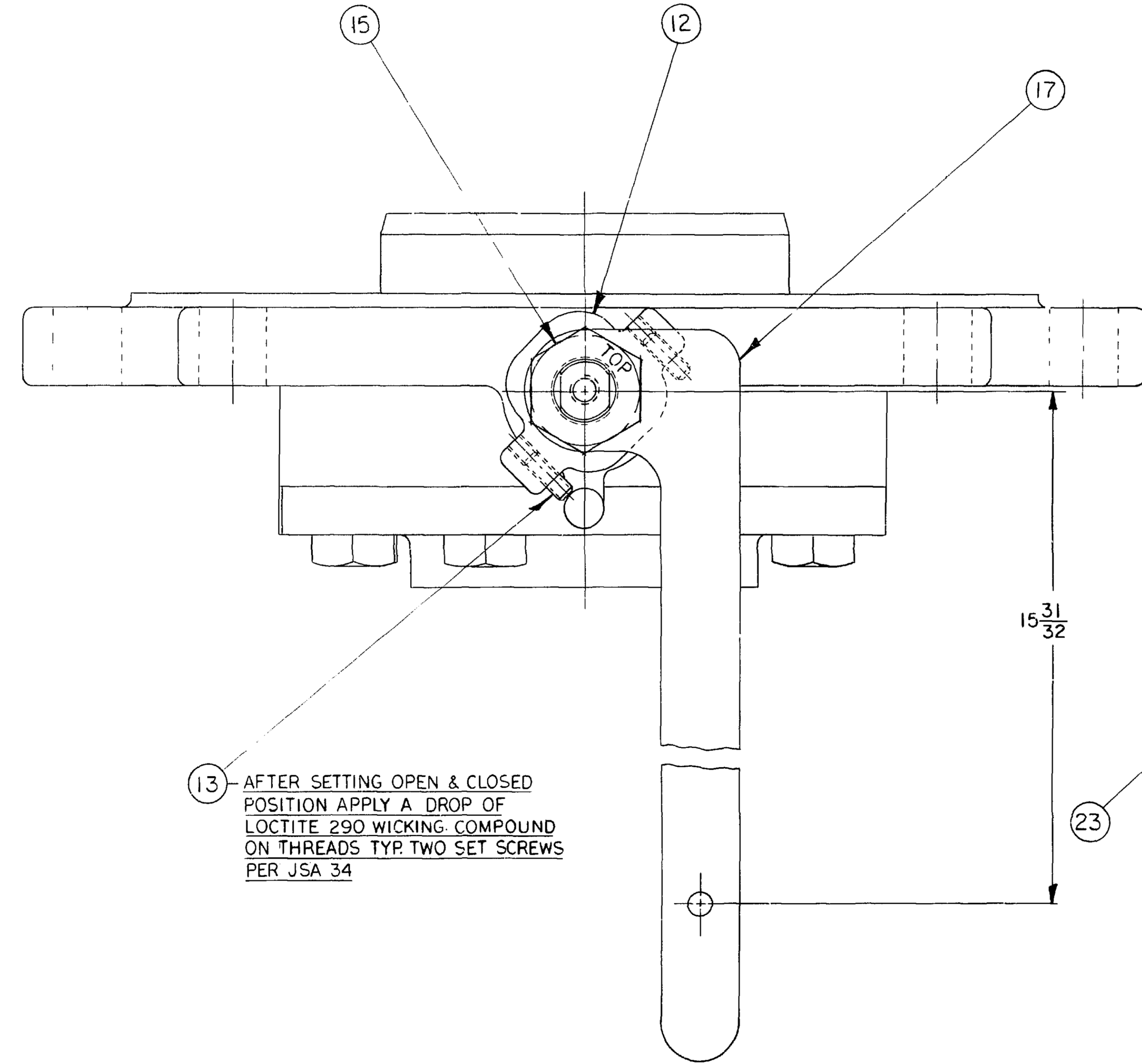

13 - AFTER SETTING OPEN & CLOSED POSITION APPLY A DROP OF LOCTITE 290 WICKING COMPOUND ON THREADS TYP. TWO SET SCREWS PER JSA 34

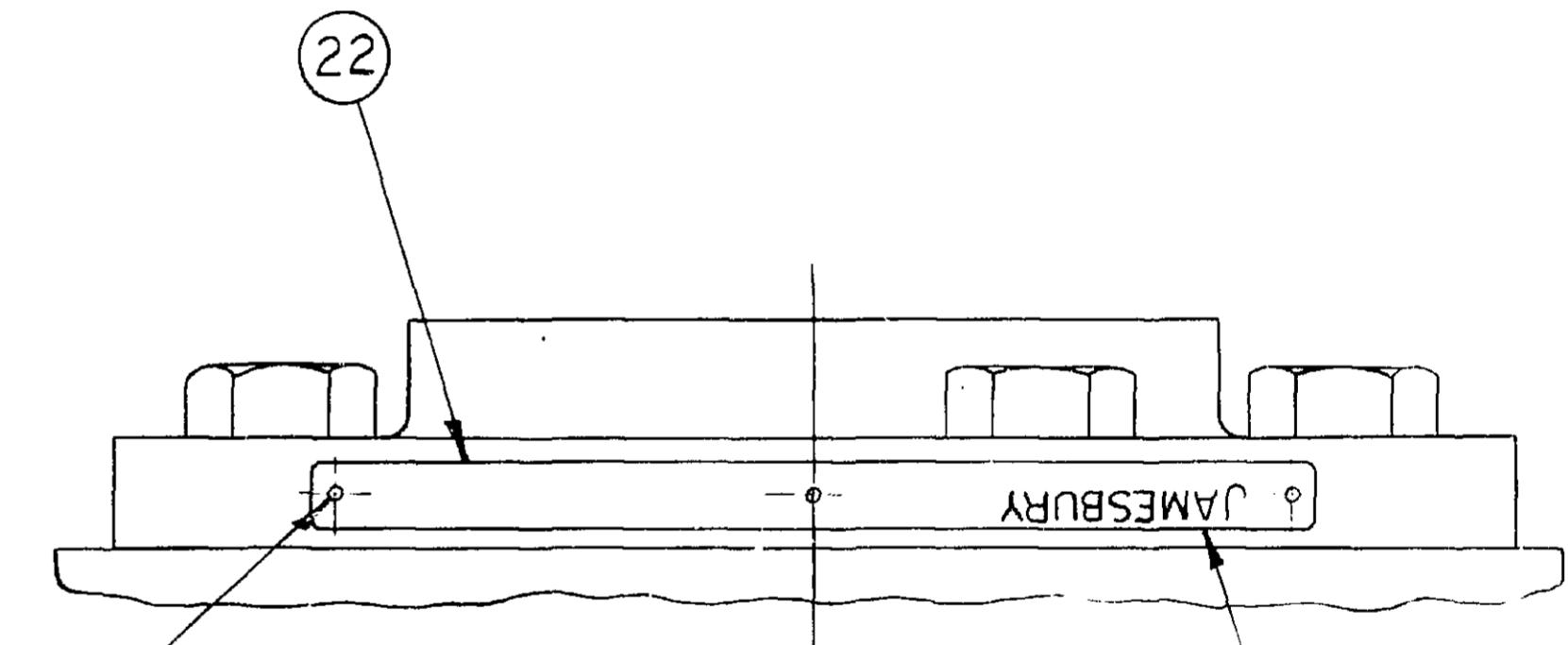

TAG MUST BE ATTACHED TO READ JAMESBURY AS SHOWN.

PARTIAL VIEW S-S

VIEW W-W

	JC	ALL
	JL	
	JM	
	JN	
	JS	
	JT	

DEFINITION OF SYMBOLS (Total Indicator Reading) ○ CONCENTRICITY ○ ROUNDNESS ○ FLATNESS ≡ SYMMETRY    PARALLEL ⊥ PERPENDICULAR	THIS DRAWING AND ALL INFORMATION CONTAINED HEREIN ARE THE PROPERTY OF THE JAMESBURY CORP. AND ARE NOT TO BE USED EXCEPT AS AUTHORIZED BY SAID CORP.  UNLESS OTHERWISE NOTED TOLERANCE FRACTIONAL ± 1/32 TWO PLACE DECIMAL ± .01 THREE PLACE DECIMAL ± .003 ANGULAR ± 1° ALL MACHINE SURFACES TO BE .250 BREAK ALL SHARP CORNERS 1/64 MAX	JAMESBURY SPECIFICATIONS APPLICABLE ON THIS DWG.	MAKE FROM PART NO.	MATERIAL SPECIFICATIONS DO NOT SCALE DRAWING	IDENTIF. MARK
		TITLE <b>ASSEMBLY</b> <b>4" 5REB3-MODEL B</b> <b>W/O STEAM JACKET</b>	OR BY DATE ECK. APR 30 2006 CH BY DATE B F APR 11 2006 DATE 11 2006	SCALE 1:1	jamesbury CORP.