

SUPERSEDING		SUPERSEDED BY			
LET	ECN	REVISION	DR.	APPVD.	DATE
---	13974	WAS: P-11500	RRH	GW	8/28/91
A	14029	SEE ECN FOR CHANGES	EVA	GW	20CT91

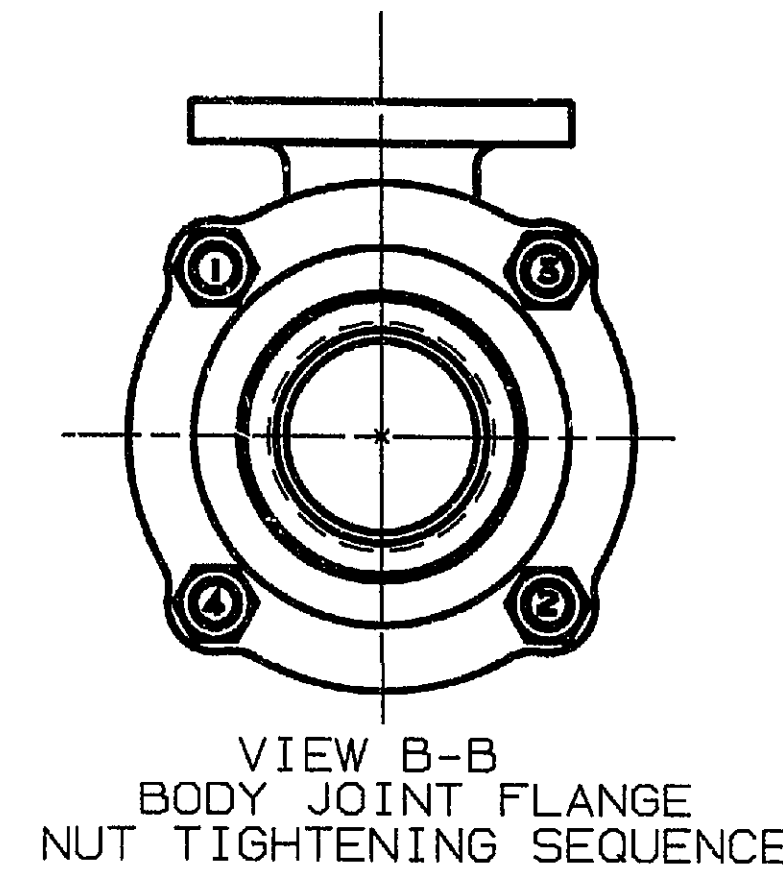
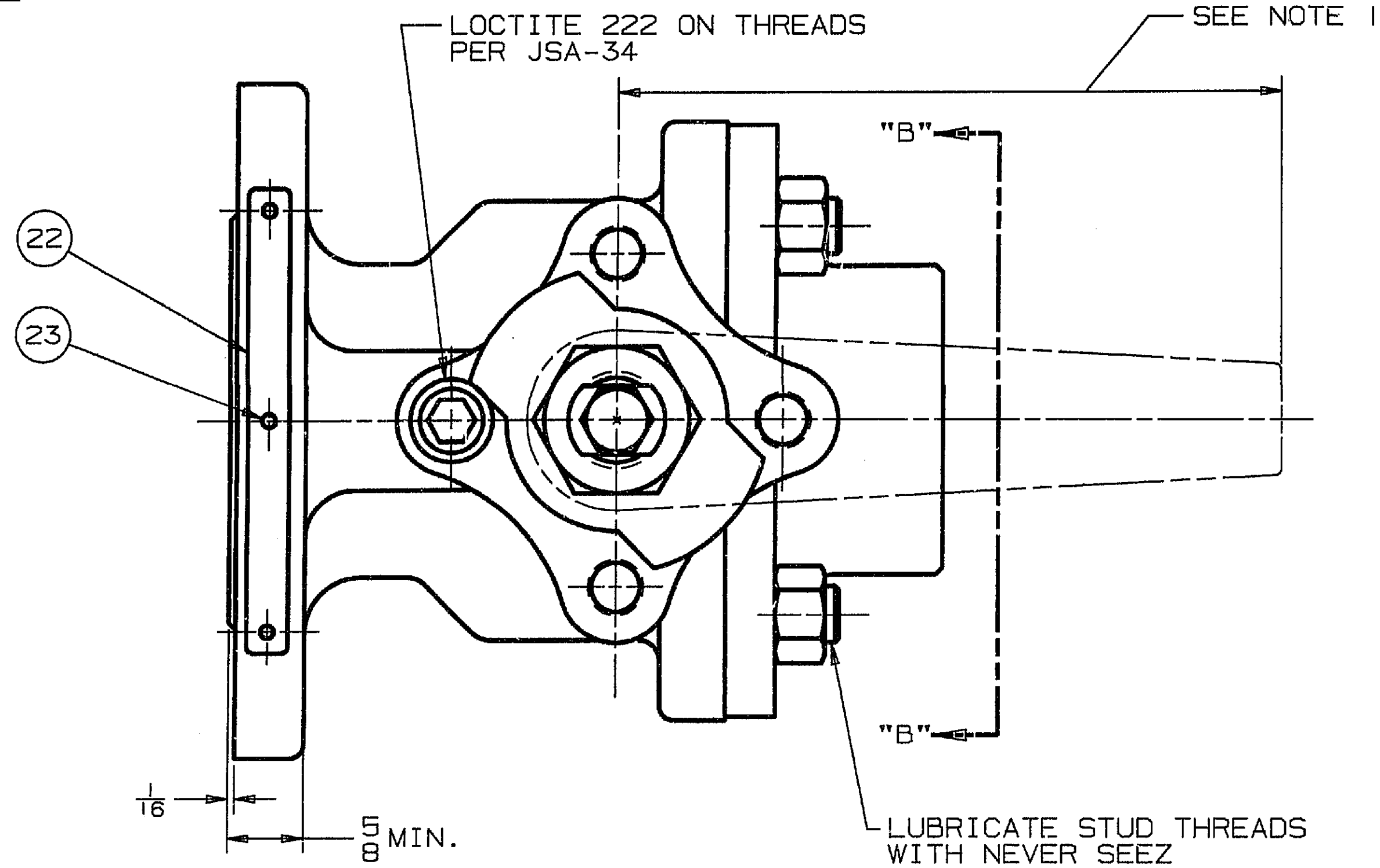

NOTE:
 1. 9" OR 6" LONG HANDLE LENGTHS AVAILABLE UPON REQUEST.
 9" = 012-0771-36
 6" = 012-0772-36

STUD & NUT MATERIAL	STUD IDENT.	NUT IDENT.	ASSEMBLY TORQUE FT-LBS
-20	B7	2H OR 2HB	75-85
-31	BB, BBC OR BBT	BB, BB8, BMB OR BTB	70-85

ITEM	PART NAME
1.	BODY
2.	BODY CAP
3.	BALL
4.	STEM
5.	SEAT
6.	BODY SEAL
7.	SECONDARY STEM SEAL
8.	LOWER STEM SEAL
10.	BODY STUD
11.	NUT
12.	INDICATOR STOP
14.	SOC. HD. CAP SCREW
15.	STEM NUT
18.	HEX HD. CAP SCREW
19.	LOCKWASHER
21.	COMPRESSION RING
22.	IDENT. TAG
23.	DRIVE SCREW/RIVET
24.	TOP STEM SEAL
33.	LOCKWASHER

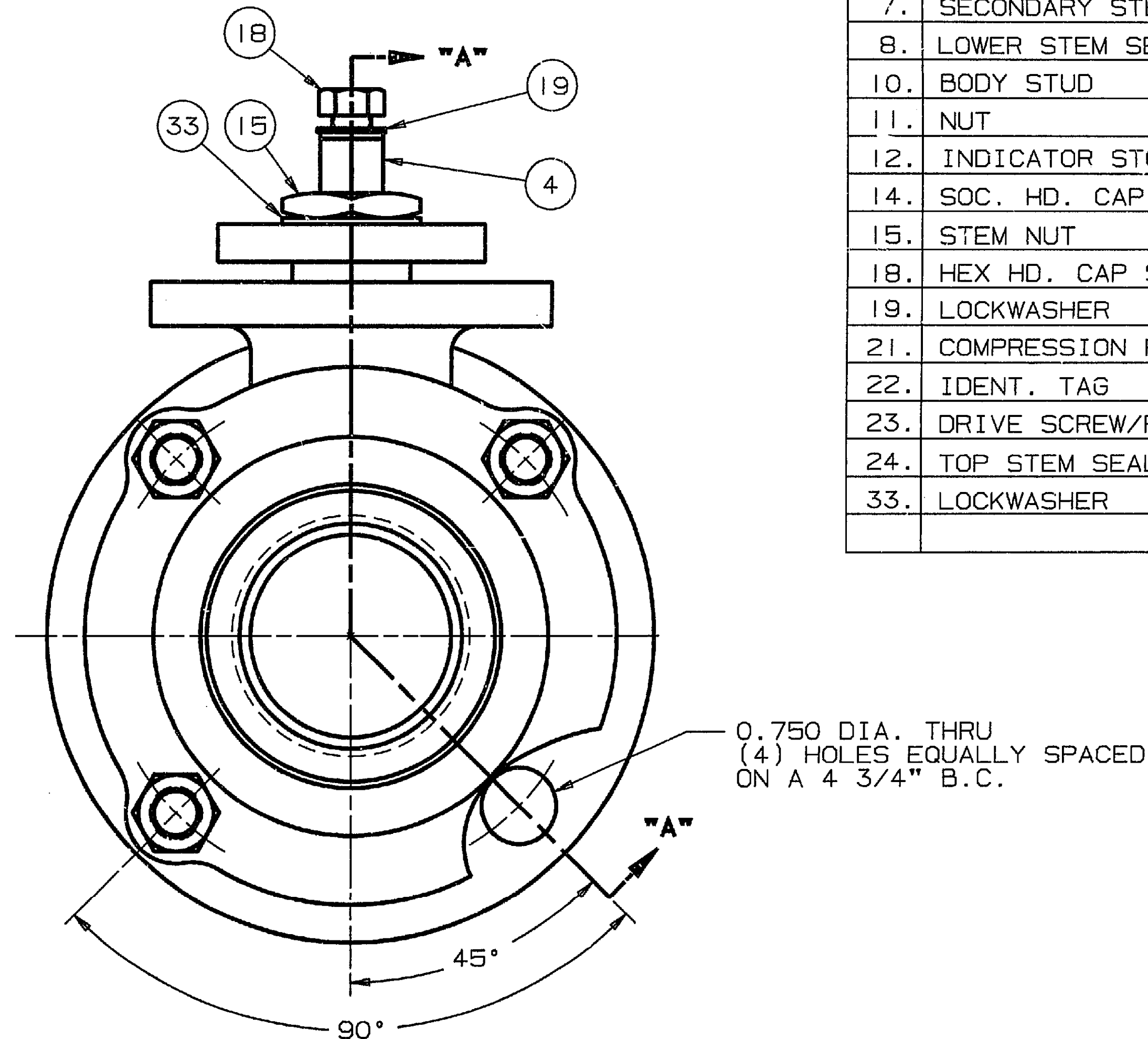
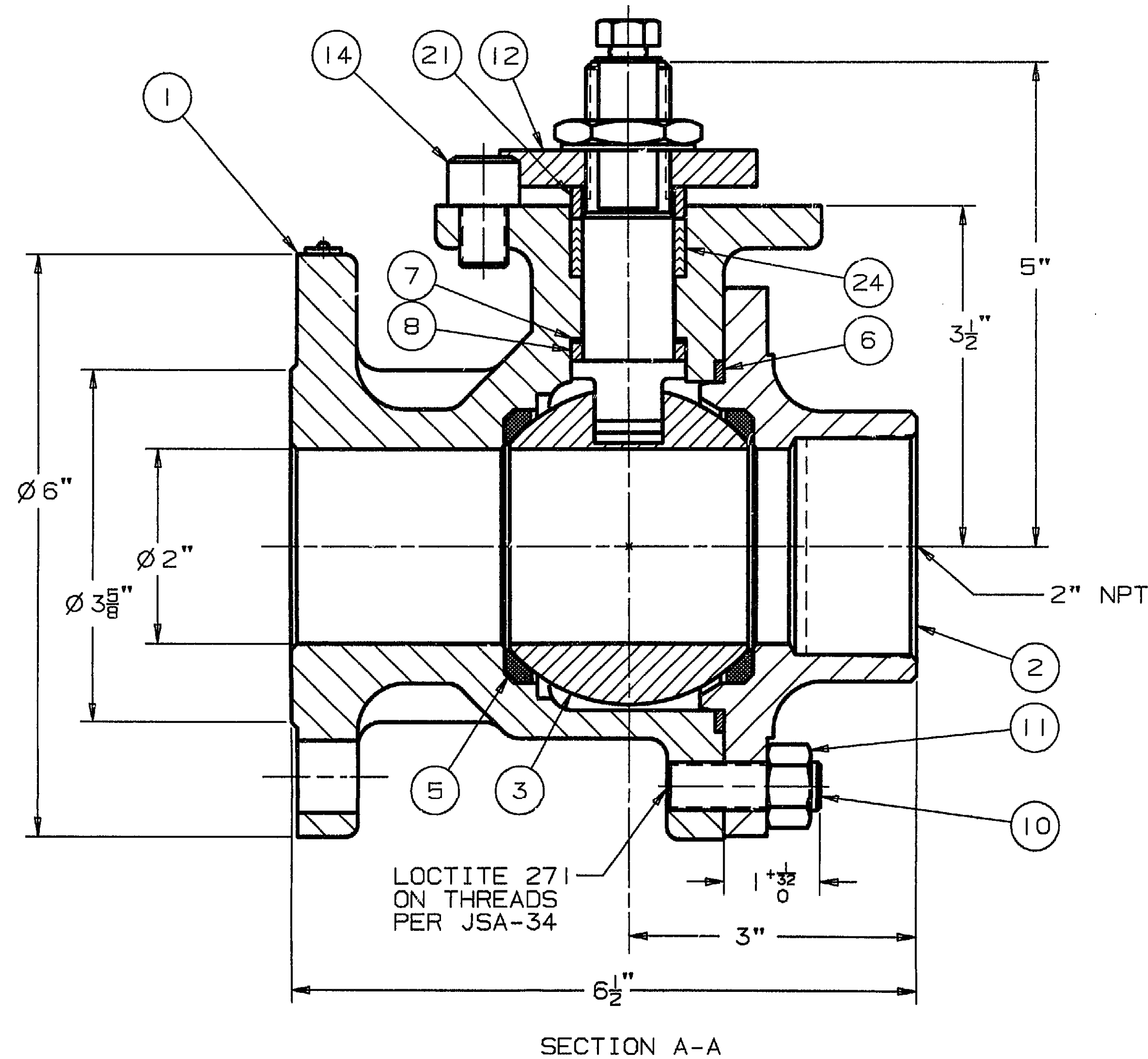

COMPUTER GENERATED

FOR JW USE ONLY

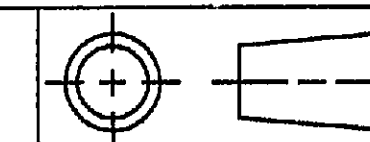

THIS DRAWING AND ALL INFORMATION CONTAINED HEREIN ARE THE PROPERTY OF THE NELES-JAMESBURY CORP. AND ARE NOT TO BE USED EXCEPT AS AUTHORIZED BY SAID CORPORATION.
 UNLESS OTHERWISE NOTED DIMENSIONING, TOLERANCING, & DRAWING INTERPRETATION IS IN ACCORDANCE WITH ANSI Y14.5-1982 & 000-STD-100.
 ALL MACHINE SURFACES TO BE 250
 BREAK ALL SHARP CORNERS 1/64 MAX.
 REMOVE ALL BURRS

MAT'L. CODE	MATERIAL TYPE	MATERIAL SPECIFICATIONS	IDENT. MARK
		DO NOT SCALE DRAWING	FULL
TITLE:		ASSEMBLY	DR. RRH DATE 28AUG91
SCALE:		2"6RFT RAILROAD VALVE	APPVD. GW DATE 28AUG91
MATERIAL SPECIFICATIONS:		JSA-01 JSA-10 JSA-17 JSA-34 JST-02	
MATERIAL TYPE:		NELES-JAMESBURY	
MATERIAL SPECIFICATIONS:		WORCESTER, MASS. U.S.A.	